

CITY OF LIVERMORE

STANDARD DETAILS

TABLE OF CONTENTS

GENERAL - G

DETAIL NO.	TITLE
G-1	TRENCH SECTION; SOIL BORING AND SMALL EXCAVATION IN THE STREET SECTION
G-2	REQUIRED SEPARATION BETWEEN WATER, SEWER, AND RECLAIMED WATER PIPELINES
G-3	STANDARD SYMBOLS
G-4	SCHEDULE OF ACCEPTABLE PIPE MATERIALS
G-5	CONCRETE CLASS USE TABLE
G-6	ABBREVIATIONS

TELECOMMUNICATION UTILITY INSTALLATION DECISION TREE:

When selecting a method for installing utilities, refer to the numbered list below, which is ordered from most preferred to least preferred.

1. For telecommunication utilities, proceed with horizontal directional boring since it is the least impactful.
2. If feasible, microtrench per City Standard Detail Plans and Specifications.
3. For the utilities that cannot be installed via horizontal directional boring or microtrenching, proceed with standard open trenching method.

User note:

These details shall be used in conjunction with all the City standard details and specifications. Refer to the City standard specifications for the materials, installation, testing, protective coatings, and other requirements.

G01A.DWG

Date	By	Rev.

TRENCH SECTION

CITY OF LIVERMORE
STANDARD DETAIL

Dwn: JK/MP/GS	Date: Jan-26
Ckd: ^{Spec.} Committee	Scale: None



City Engineer

No.
G-1A
SHEET
1 OF 2

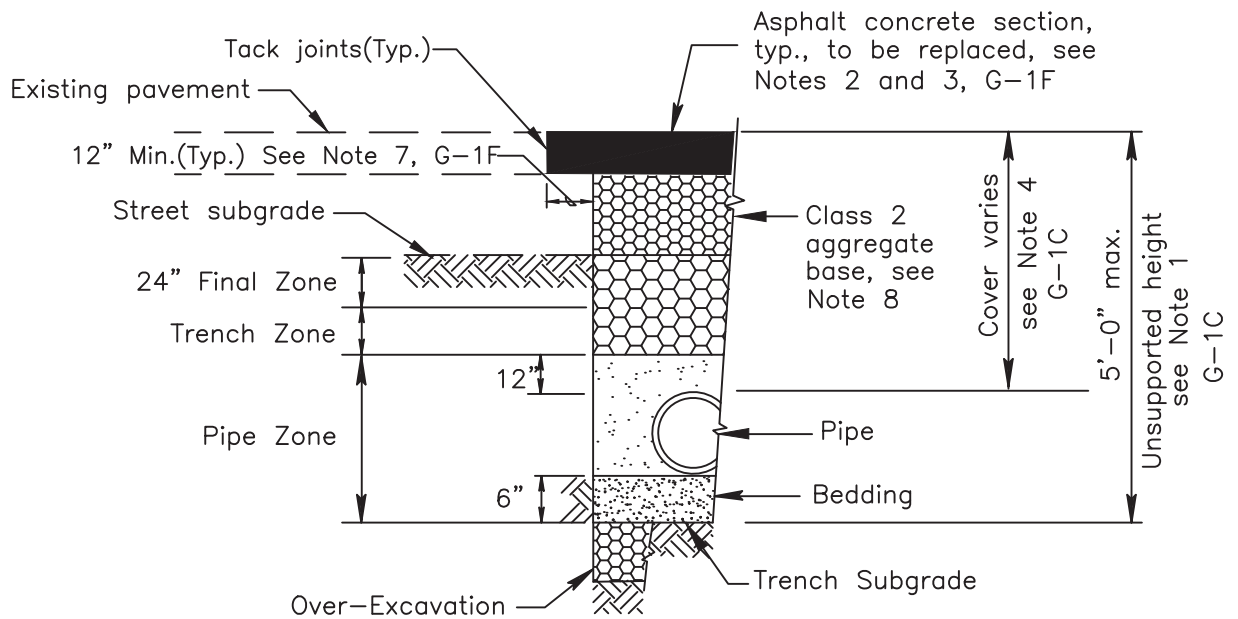

EXISTING STREET

(NON-ARTERIAL OR COLLECTOR)

Note: See G-1E for Street Classification

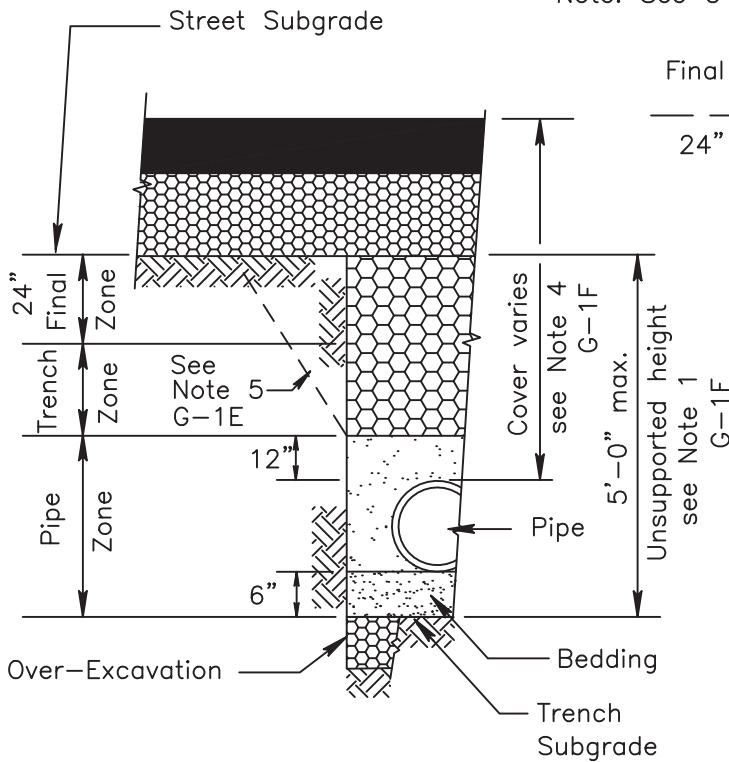

NEW STREET

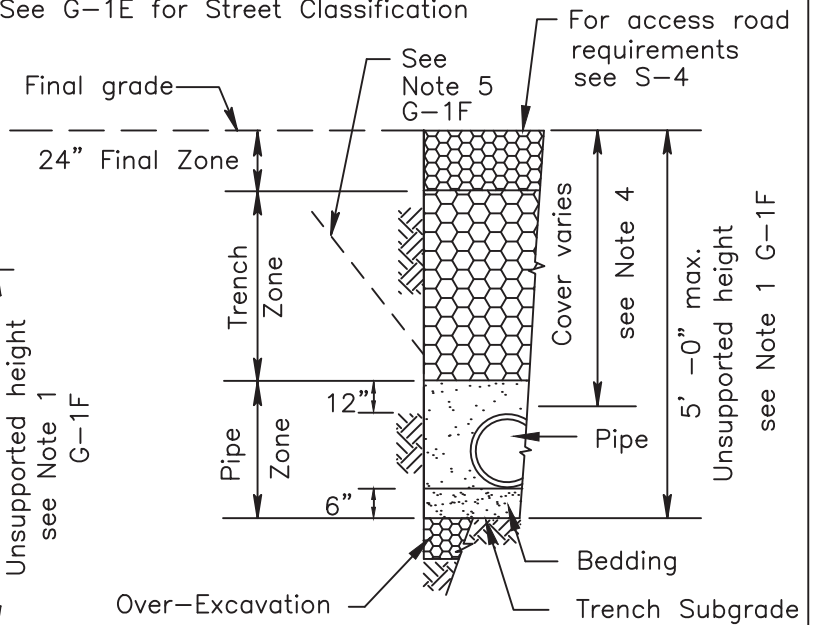

UNIMPROVED AREAS

User note:
 These details shall be used in conjunction with all the City standard details and specifications. Refer to the City standard specifications for the materials, installation, testing, protective coatings, and other requirements.

G01A.DWG

Date:	By:	Rev:

TRENCH SECTION

**CITY OF LIVERMORE
 STANDARD DETAIL**

Dwn: KY/HI/GS Date: Jan-26

Ckd: Spec. Committee Scale: None

John Warden
 City Engineer

No.
G-1A
 SHEET
 2 OF 2

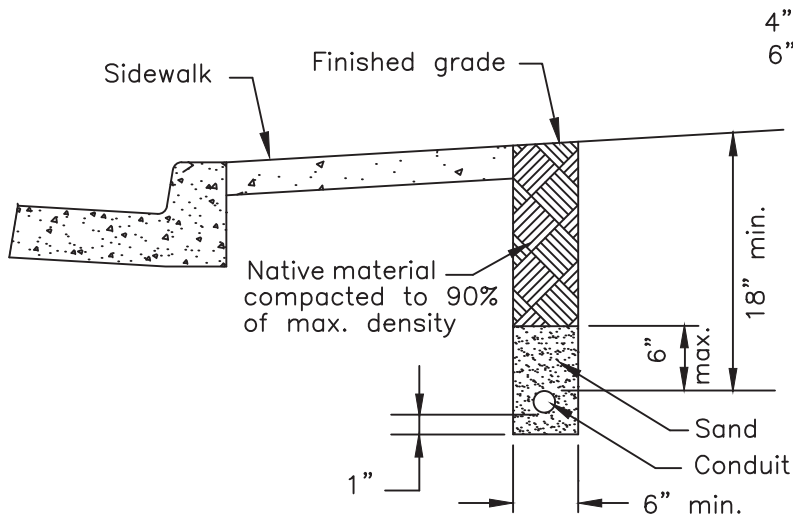

STREET LIGHT CONDUIT TRENCH SECTION (WHEN NOT IN JOINT TRENCH)

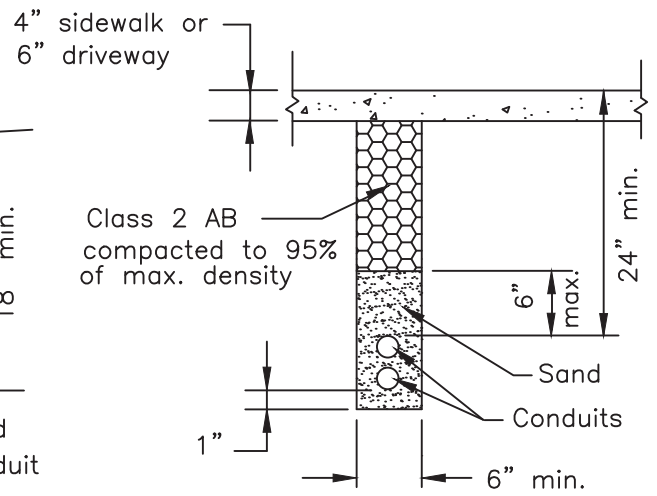

TRAFFIC SIGNAL CONDUIT TRENCH SECTION UNDER SIDEWALKS/DRIVEWAYS

NOTES:

1. In existing street, the asphalt concrete thickness replaced shall not be less than 6", or match the existing asphalt concrete section, whichever is greater.

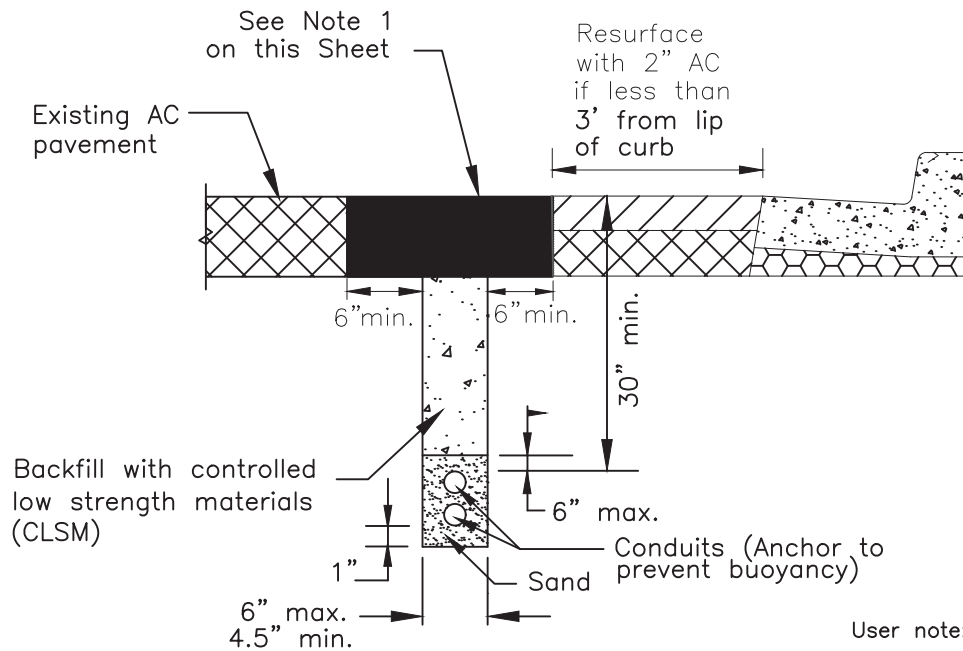

User note:
 These details shall be used in conjunction with all the City standard details and specifications. Refer to the City standard specifications for the materials, installation, testing, protective coatings, and other requirements.

TELECOMMUNICATIONS CONDUIT TRENCH SECTIONS (ELECTRICAL, TRAFFIC SIGNAL CONDUITS, STREET LIGHT CONDUIT CROSSINGS, TELEPHONE, CABLE TV / COMMUNICATION CONDUITS)

G01B.DWG

Date	By	Rev.

TRENCH SECTION

CITY OF LIVERMORE
 STANDARD DETAIL

Dwn: KY/HI/GS	Date: Jan-26	No.
Spec. Ckd: Committee	Scale: None	G-1B
 City Engineer		SHEET 1 OF 2

NOTES:

1. Microtrenching is not allowed for any street section that is greater than 18" in depth.
2. Trace conduit to determine installed depth before trench restoration. If the conduits are less than the minimum required depth, then conduits are to be repaired/relocated such that they are reset at the correct min. depth before beginning surface restoration.
3. A tracer wire shall be installed inside each conduit installed and/or made part of the fiber shielding for the fiber installed inside the conduit.
4. In existing street, the asphalt concrete thickness replaced shall not be less than 6", or match the existing asphalt concrete section, whichever is greater.

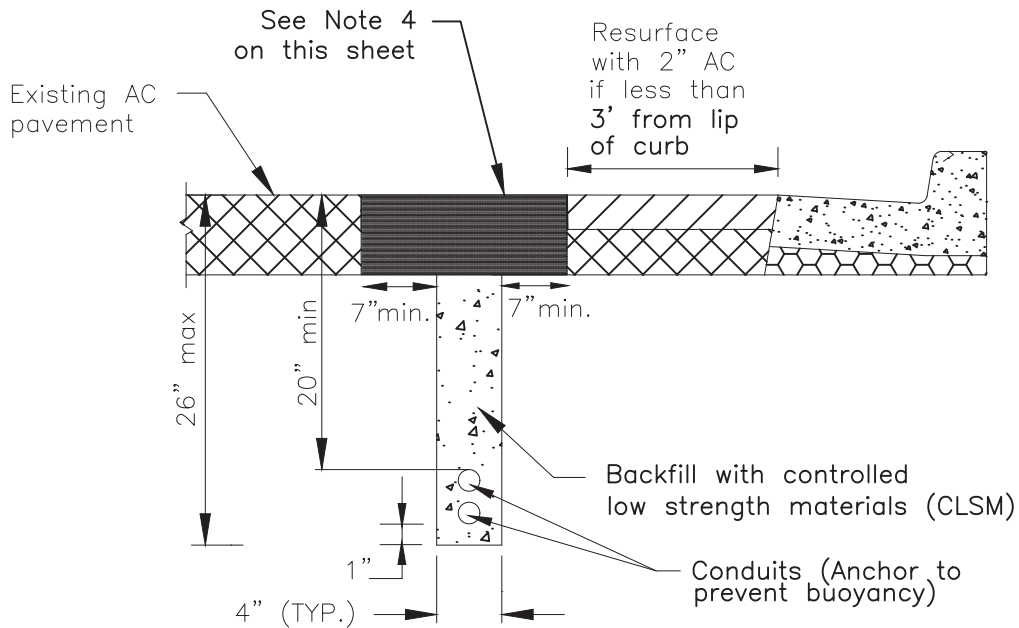

MICROTRENCH SECTION

User note:
 These details shall be used in conjunction with all the City standard details and specifications. Refer to the City standard specifications for the materials, installation, testing, protective coatings, and other requirements.

Date	By	Rev.

TRENCH SECTION

CITY OF LIVERMORE
 STANDARD DETAIL

Dwn: KY/HI/GS	Date: Jan-26	No.
Ckd: Spec. Committee	Scale: None	G-1B SHEET 2 OF 2
 City Engineer		

G01B.DWG

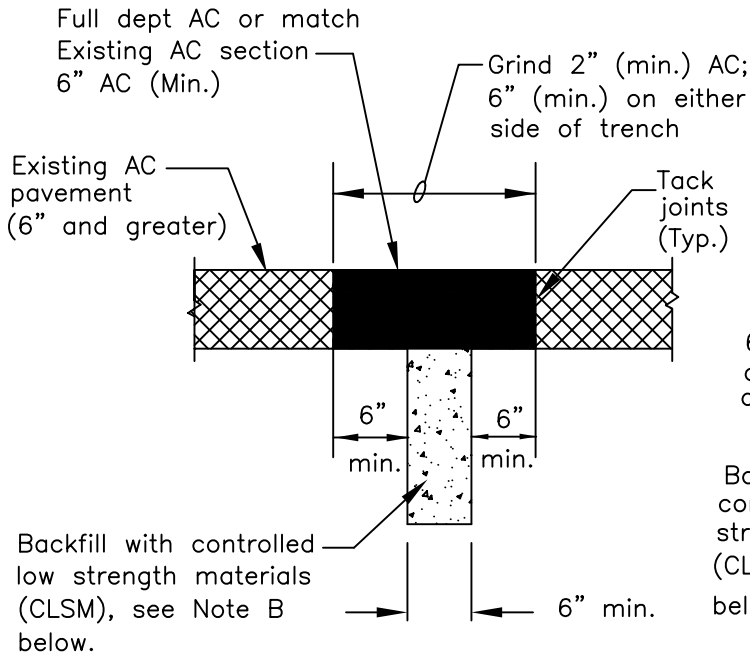

SECTION "A"
FOR EXISTING ASPHALT CONCRETE
SECTIONS 6" AND GREATER

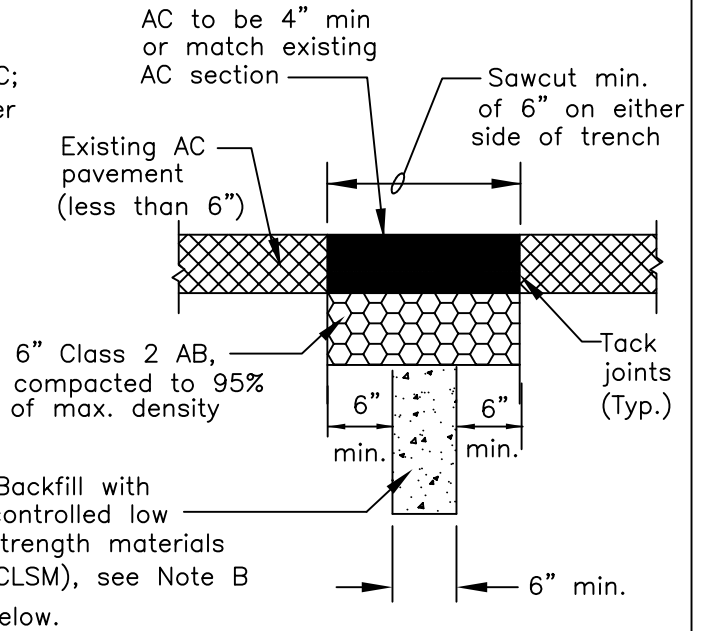

SECTION "B"
FOR EXISTING ASPHALT CONCRETE
SECTIONS LESS THAN 6"

NOTES

- A. PRIOR TO TRENCHING, CONTACT USA 1-800-227-2600
- B. CONTROLLED LOW STRENGTH MATERIALS (CLSM) SHALL BE A FLOWABLE, HAND-EXCAVATABLE MIXTURE OF CEMENT, POZZOLAN, COARSE AND FINE AGGREGATE, ADMIXTURES AND WATER WHICH HAS BEEN MIXED IN ACCORDANCE WITH ASTM C 94. ALL PROPERTIES, COMPOSITIONS AND INSTALLATION REQUIREMENTS SHALL BE PER SPECIFICATION SECTION 312323. (CLSM) SHALL NOT COME IN CONTACT WITH UTILITIES. MAINTAIN A CLEARANCE OF 6" MINIMUM BETWEEN CLSM AND UTILITIES FOR BACKFILL.
- C. ANY EXCAVATIONS LARGER THAN 3'x3' SHALL COMPLY WITH CITY STD DETAIL G-1B.

User note:

These details shall be used in conjunction with all the City standard details and specifications. Refer to the City standard specifications for the materials, installation, testing, protective coatings, and other requirements.

G01C.DWG

Date:	By:	Rev:

SOIL BORING AND
 SMALL EXCAVATION IN STREET
 SECTION

CITY OF LIVERMORE
 STANDARD DETAIL

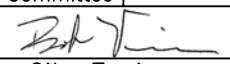
Dwn: MAP/HI	Date: Feb-23	No. G-1C
Ckd: Spec. Committee	Scale: None	
 City Engineer		

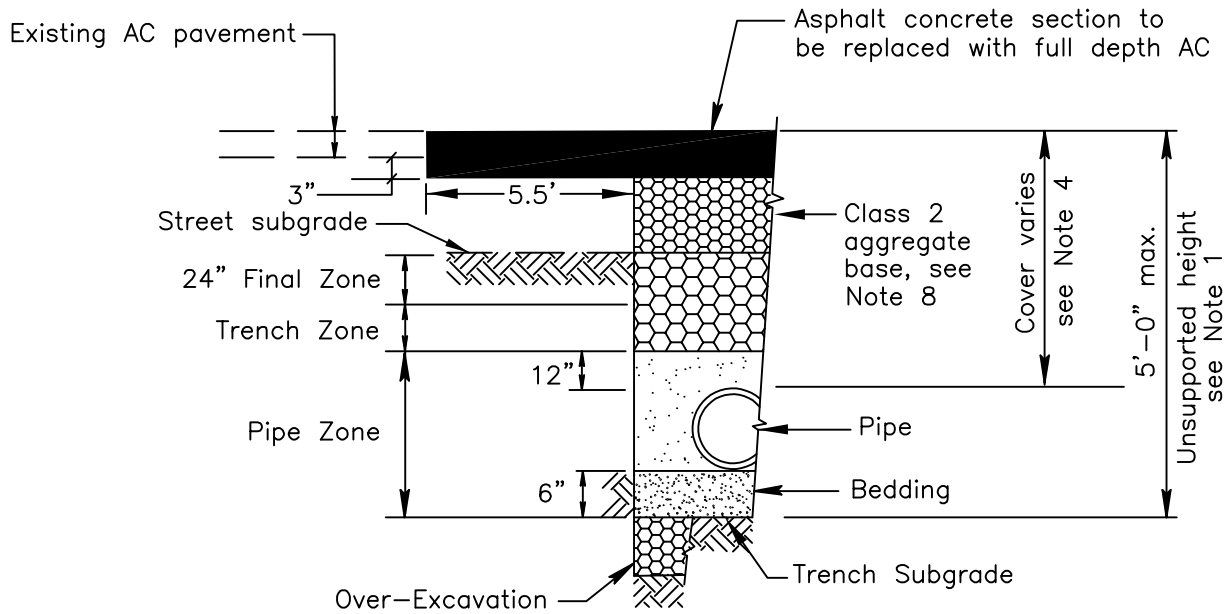

PAVEMENT LESS THAN 6"

*More than 50% grind weakens remaining base lift

**Caltrans Sec. 39.304 Pave HMA in Max 0.25 foot thick compacted layers

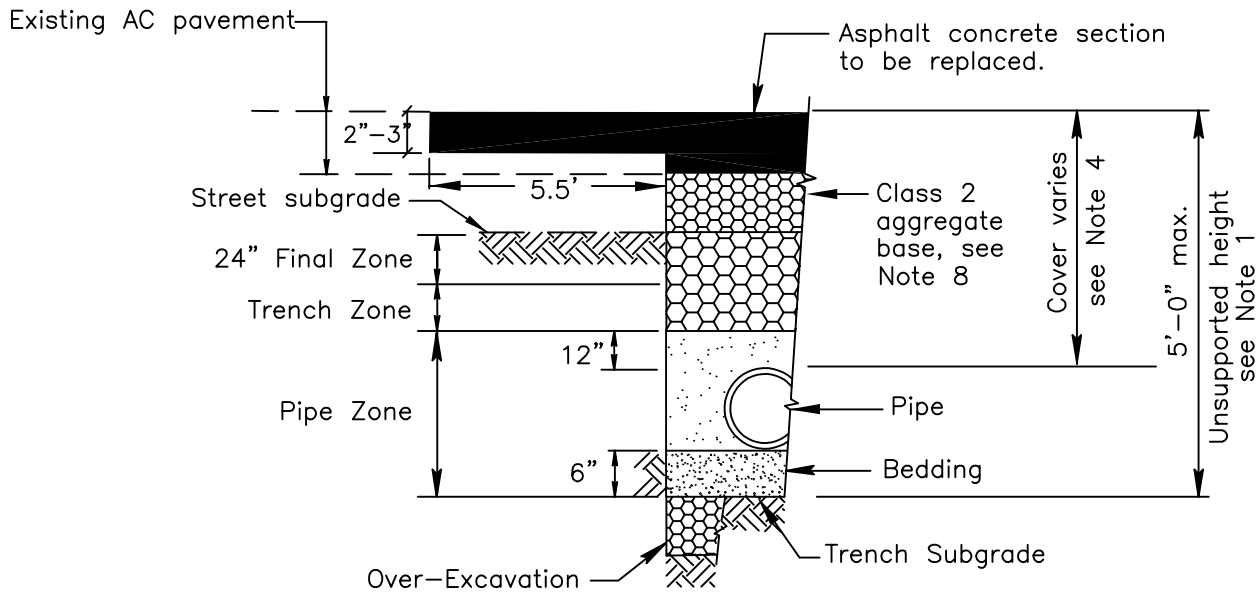

PAVEMENT GREATER THAN 6"

User note:

These details shall be used in conjunction with all the City standard details and specifications. Refer to the City standard specifications for the materials, installation, testing, protective coatings, and other requirements.

Note: Refer to City Standard Detail No. G-1F for applicable street classification.

G01E.DWG

Date:	By:	Rev:

TRENCH PAVEMENT REPAIR
ARTERIALS AND COLLECTORS

CITY OF LIVERMORE
STANDARD DETAIL

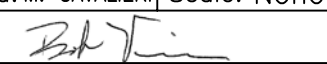
Dwn: M. IRBY/HI	Date: Feb-23	No.
Ckd: M. CAVALIERI	Scale: None	G-1D
 City Engineer		

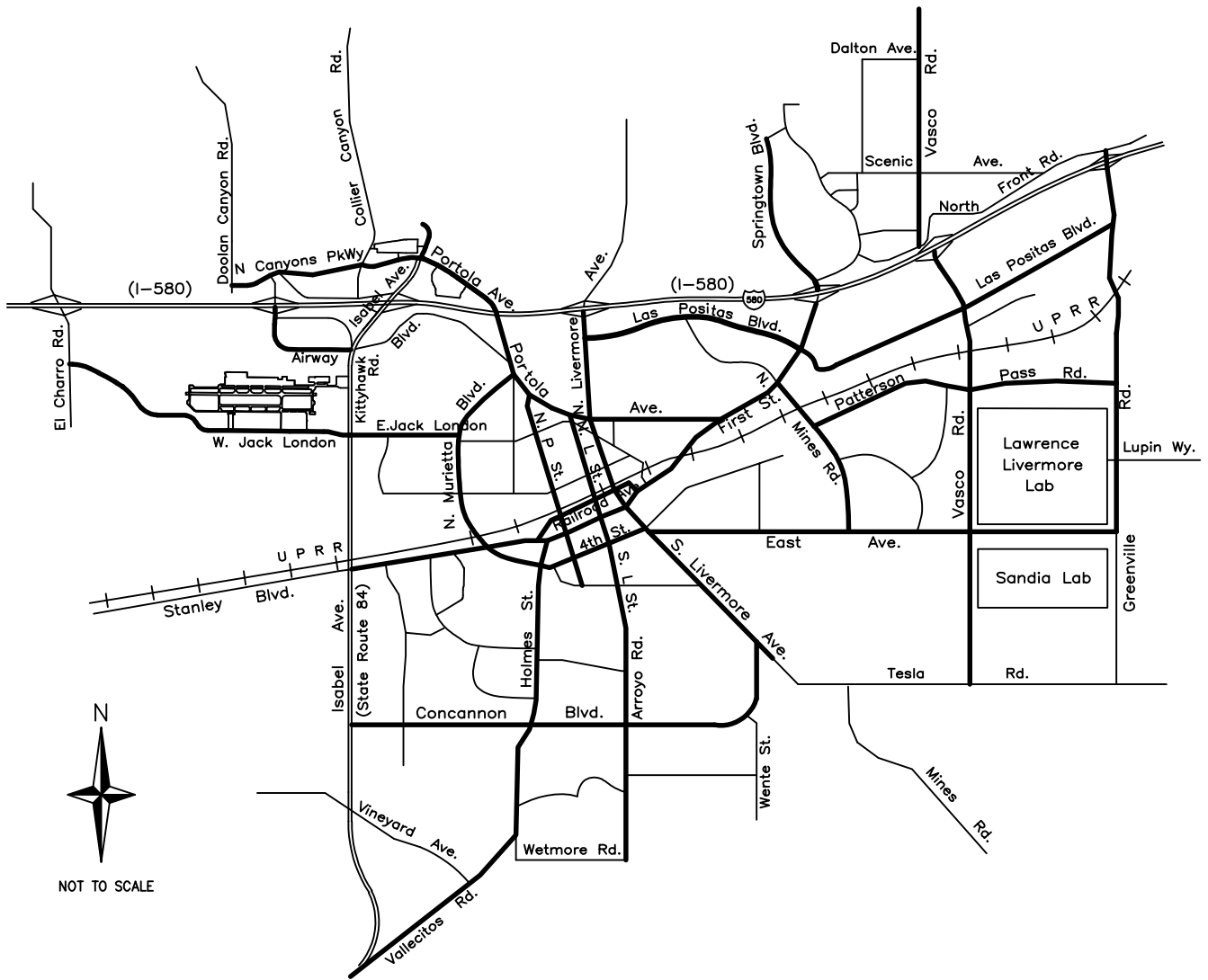

NOT TO SCALE

- ARTERIALS
- COLLECTORS

User note:
 These details shall be used in conjunction with all the City standard details and specifications. Refer to the City standard specifications for the materials, installation, testing, protective coatings, and other requirements.

G01E.DWG

TRENCH PAVEMENT REPAIR ARTERIALS AND COLLECTORS LOCATION MAP

CITY OF LIVERMORE STANDARD DETAIL

Dwn: MM-HI	Date: Feb-23	No.
Ckd: Spec Comm	Scale: None	G-1E
Acting City Engineer		

Date:	By:	Rev:	
-------	-----	------	--

NOTES:

1. Trenching shall conform to the "Construction Safety Orders of the State of California" and Section 6705 of the California Labor Code.
2. In existing streets, the total asphalt concrete thickness replaced shall not be less than 6" (4" in residential streets), or match the existing asphalt concrete section, whichever is greater.
3. In existing streets the asphalt concrete bottom lift(s) shall not be less than 4" (2" in residential streets), and the asphalt concrete top lift shall not be less than 2".
4. Where adequate compaction cannot be achieved due to obstruction or other conditions, replace pipe zone and/or trench zone fill with Controlled Low Strength Material (CLSM) as directed by the ENGINEER.
5. Sloping trench sections, above pipe zone, can only be used where stable compact soil conditions exist, where approved by the ENGINEER, or where shown on the drawing or specifications. Sloping trench sections will not be allowed in existing streets.
6. Prior to trenching, contact USA 1-800-227-2600
7. Before pavement section is replaced, the existing pavement shall be sawcut at least 12 inches back from trench excavation along neat, straight, parallel lines. [Where the existing asphalt concrete is 6" or more in thickness or where the repaving is less than 15 square feet in area, sawcut may be the edge of the trench excavation.] Expect for Arterial and Collector Street (See G-1D). Where wall of trench excavation is within 18" of the lip of gutter replace AC from trench wall to lip of gutter. All AC and concrete areas shall be tack coat prior to paving.
8. In existing streets the total aggregate base shall be the greater of the existing street aggregate base section or the following minimum aggregate base:
 - a) Local, loops, cul-de-sac, and private residential streets: 12" AB (min.)
 - b) Collector, frontage, major, and industrial/commercial streets: 18" AB (min.)
9. See the "Utility Earthwork" section of the City standard specifications 31.2300 for compaction requirements, metric specifications and additional information.
10. Edge sealing, the application of asphalt material along the edges of a patch. This ensures water cannot penetrate the patch seam.

User note:
 These details shall be used in conjunction with all the City standard details and specifications. Refer to the City standard specifications for the materials, installation, testing, protective coatings, and other requirements.

G01C.DWG

TRENCH SECTION			CITY OF LIVERMORE				
			STANDARD DETAIL				
			Dwn: M-W/KY/HI	Date: Jan-23	No.		G-1F
			Ckd: ^{Spec.} Committee	Scale: None			
			 City Engineer				
Date	By	Rev.					

BASIC SEPARATION STANDARDS:

1. Parallel construction: The horizontal clear distance between pressure domestic water and reclaimed water mains and sewer lines shall be at least 10 feet clear.
2. Perpendicular construction (Crossing): Pressure water mains shall be at least one (1) foot clear above sanitary sewer and reclaimed water lines where these lines must cross.
3. The basic separation standard are applicable under normal conditions for sewer lines and water distribution lines. More stringent requirements as determined by the State Health Department may be necessary if conditions, such as, high ground water exist.
4. Special Provisions: Alternative construction criteria where the basic separation standards cannot be attained are shown below and on G-2B:

SPECIAL PROVISIONS GENERAL NOTES (SEE G-2B):

1. No pipe joints shall be permitted within Zones C and D.
2. All DIP must have hot DIP bituminous coating and all Class 200 PVC must meet DR-14 per AWWA C900 or equivalent.
3. Sewer force mains shall not be permitted in Zones A through D.
4. This criteria does not apply for a reclaimed water line crossing another reclaimed water line.
5. The construction criteria should apply to the house laterals that cross above a pressure water main but not to those house laterals that cross below a pressure water main.
6. Construction for sewer and domestic water or reclaimed water lines 24" diameter or larger will not be allowed without the approval of the Engineer and the State Health Department.
7. See G-2B for applicable situations.

User note:
 These details shall be used in conjunction with all the City standard details and specifications. Refer to the City standard specifications for the materials, installation, testing, protective coatings, and other requirements.

G2A.DWG

Date:	By:	Rev:

REQUIRED SEPARATION
 BETWEEN WATER, SEWER
 AND RECLAIMED WATER
 PIPELINES

CITY OF LIVERMORE
 STANDARD DETAIL

Dwn: KY	Date: May-13	No.
Ckd: ^{Spec.} Committee	Scale: None	G-2A
 City Engineer		

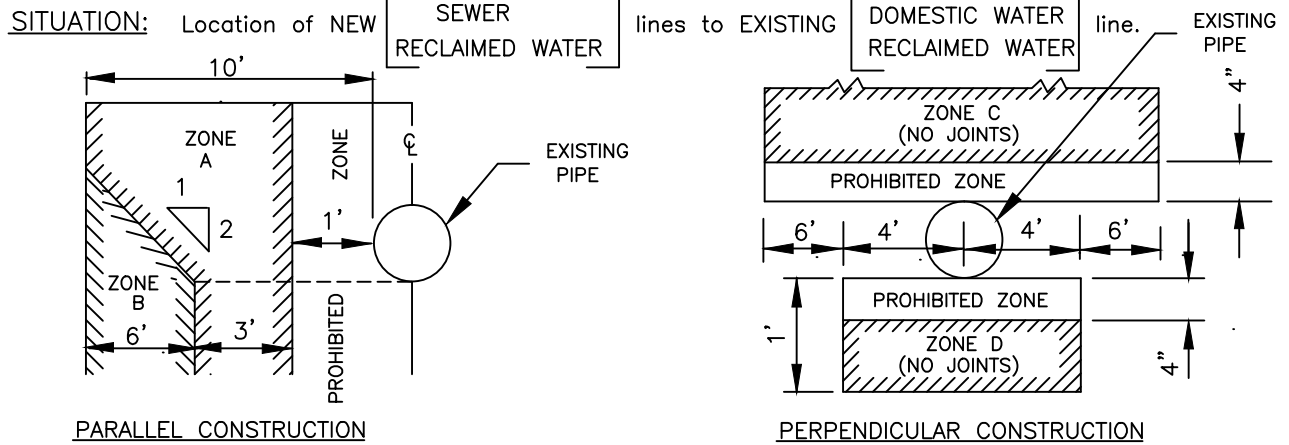

If any sewer or reclaimed water pipelines are to be constructed within any of the above indicated Zones, special construction shall be required as described below.

Construction Requirements

ZONE NEW SEWER:

- A Do not locate any parallel sewer lines in this area without State and Local Health Department Approval.
- B Use VCP, PVC sewer pipe with rubber ring joints, or DIP with compression joints.
- C Use DIP with mechanical joints or PVC Class 200 – AWWA C900
- D Use DIP or PVC Class 200 – AWWA C900

ZONE NEW RECLAIMED WATER:

- A Do not locate any parallel reclaimed water line in this area without State and Local Health Department Approval.
- B Use DIP or PVC Class 200 – AWWA C900
- C Use DIP or PVC Class 200 – AWWA C900
- D Use DIP or PVC Class 200 – AWWA C900

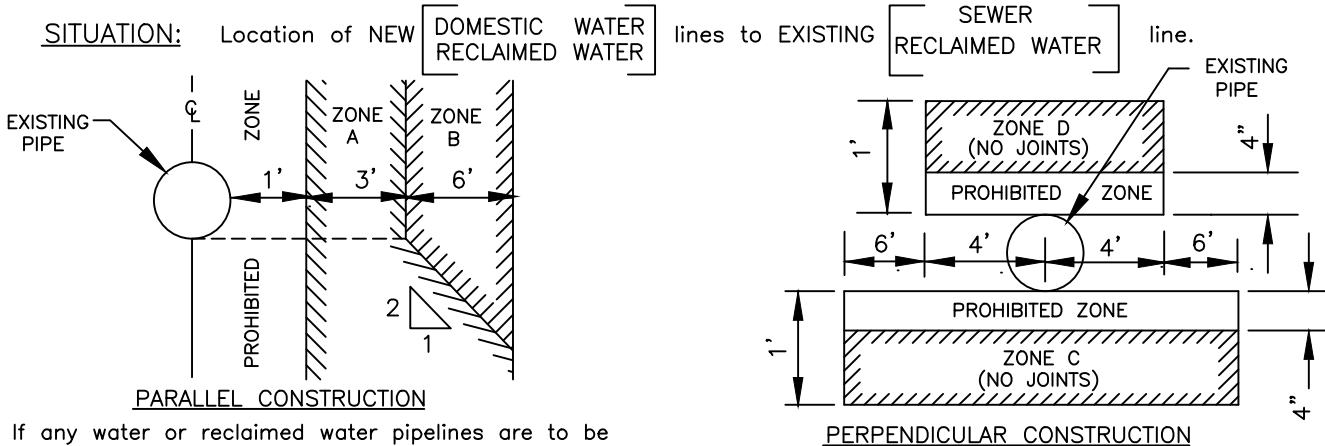

If any water or reclaimed water pipelines are to be constructed within any of the above indicated Zones, special construction shall be required as described below.

Construction Requirements

ZONE NEW DOMESTIC OR RECLAIMED WATER:

- A Do not locate any parallel domestic water or reclaimed water main in this area without State and Local Health Department Approval.
- B Use DIP or PVC Class 200 – AWWA C900
- C Use DIP or PVC Class 200 – AWWA C900
- D Use DIP or PVC Class 200 – AWWA C900

User note:

These details shall be used in conjunction with all the City standard details and specifications. Refer to the City standard specifications for the materials, installation, testing, protective coatings, and other requirements.

REQUIRED SEPARATION BETWEEN WATER, SEWER AND RECLAIMED WATER PIPELINES

CITY OF LIVERMORE STANDARD DETAIL

Dwn: KY	Date: May-13	No.
Kcd: Spec. Committee	Scale: None	G-2B
 City Engineer		

Date:	By:	Rev:

04/20/13

EXISTING

PROPOSED

DESCRIPTION

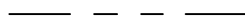
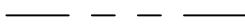

PROPERTY LINE

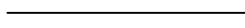
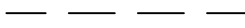

SIDEWALK, CURB @ GUTTER

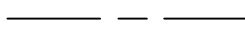
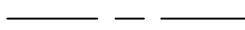

CENTERLINE

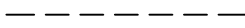

EDGE OF PAVEMENT

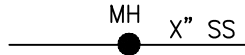
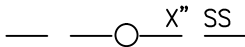

SANITARY SEWER & MAINTENANCE HOLE

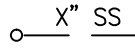

SANITARY SEWER & RISER

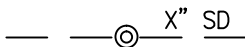

STORM SEWER & MAINTENANCE HOLE

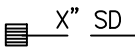

STORM SEWER & INLET



WATER MAIN

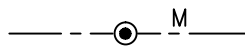
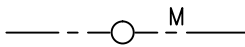

MONUMENT LINE & MONUMENT



UTILITY POLE



TRAFFIC SIGN

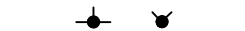

FIRE HYDRANT - ● commercial
- ♣ residential

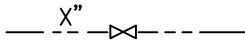

WATER MAIN & VALVE

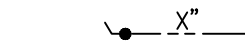
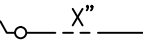

WATER MAIN & BLOW-OFF

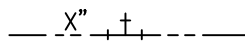
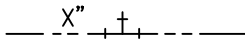

WATER MAIN & TEE

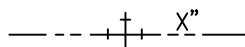

WATER MAIN & CROSS

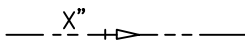

WATER MAIN & REDUCER

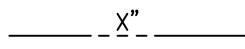
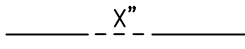

GAS MAIN

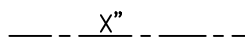
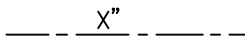

TELEPHONE CONDUIT

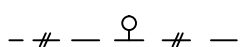

ELECTROLIER & CONDUIT

X" = indicate size in inches

G03.DWG

Date	By	Rev.

STANDARD
SYMBOLS

CITY OF LIVERMORE
STANDARD DETAIL

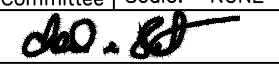
Dwn: KY	Date: May-13	NO. G-3
Ckd: Spec. Committee	Scale: NONE	
 City Engineer		

PIPE TYPE IDENTIFICATION	PIPE TYPE USAGE	APPROVED PIPE MATERIALS (1)	REFERENCE TO NOTES	SPEC. SECTION
STORM DRAIN (SD)	Mains and Laterals	ABS/PVCsdnpp	4, 7	333104
		HDPE	7	334100
		RCP	7	334102
		CIPCP	2	033050
		DIP		055900
	Force Main	PVCpp		331102
		DIP		055900
SANITARY SEWER (SS)	Trunk Main (Major) 30" and larger	RCP(PVCL)	7	333100
	Trunk Main (Minor) Larger than 15" and less than 30"	VCP/PVCsdnpp	4, 7	333106/ 333104
	Force Main	PVCpp		331102
		DIP		055900
	Street Main, Up to 15"	ABS/PVC Composite	7	333102
		ABS/PVCsdnpp	7	333104
		VCP	7	333106
		DIP	7	055900
	Service Lateral	ABS/PVC Composite		333102
		ABS/PVCsdnpp		333104
		VCP		333106
DIP			055900	
WATER (W)	Distribution Main, Up to 12"	PVCpp		331102
		DIP		055900
	Transmission Main, Larger than 12"	PVCpp		331102
		MLCSP	2	331104
		DIP	2	055900
	1" Residential Domestic/ Fire Service Lateral	PE		331200
	1", 1-1/2", & 2" Service Lateral	PE		331200
	4" and larger Industrial/Commercial Fire Service Lateral	PVCpp		331102
		DIP	2	055900
	Fire Hydrant Lateral	PVCpp	3	331102
MLCSP		2	331104	
		DIP		055900

SEE G-4B

User note:
These details shall be used in conjunction with all the City standard details and specifications. Refer to the City standard specifications for the materials, installation, testing, protective coatings, and other requirements.

Date:	By:	Rev:

SCHEDULE OF ACCEPTABLE PIPE MATERIALS

CITY OF LIVERMORE STANDARD DETAIL

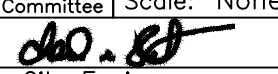
Dwn: M-W	Date: May-13	No.
Ckd: <small>Spec. Committee</small>	Scale: None	G-4A
 City Engineer		

G04A.DWG

<u>PIPE TYPE IDENTIFICATION</u>	<u>PIPE TYPE USAGE</u>	<u>APPROVED PIPE MATERIALS</u> (1 & 6)	<u>REFERENCE TO NOTES</u>	<u>SPEC. SECTION</u>
---------------------------------	------------------------	---	---------------------------	----------------------

RECLAIMED WATER	Distribution Main, Up to 12"	PVCpp DIP		331102 055900
	Transmission Main, Larger than 12"	PVCpp DIP	2	331102 055900
	Fire Hydrant Lateral	PVCpp DIP		331102 055900
	Irrigation	PVCpp PVCpp		331102 328000

Notes:

1. Pipe material types shall be selected according to the service and function listed. Services or functions not identified or pipe types not listed require specific written approval of the ENGINEER. Pipe materials shall be in strict accordance with the City Standard Specifications.
2. Use of pipe material type requires written approval of the ENGINEER.
3. In City of Livermore water service area, where water main is MLCSP and when required by the ENGINEER, Fire Hydrant Laterals shall be MLCSP.
4. All PVCsdnpp for Storm Drain mains and Sanitary Sewer Trunk Mains (Minor) greater than 15" shall have a maximum SDR of 26 and a minimum pipe stiffness of 115 psi.
5. In areas of corrosive soils, high ground water tables and other adverse conditions, the pipe material shall be as specified by the ENGINEER.
6. See the City's latest "Guidelines for the use of Reclaimed Water" for information and requirements for connection to the City's reclaimed water system.
7. See City's latest Development Plan Check and Procedures Manual for City Pipe Design Criteria. A registered Civil Engineer shall provide deflection/load calculations for all Storm Drain and Sewer Main pipes in accordance with the City's Pipe Design Criteria.

User note:
These details shall be used in conjunction with all the City standard details and specifications. Refer to the City standard specifications for the materials, installation, testing, protective coatings, and other requirements.

SCHEDULE OF ACCEPTABLE
PIPE MATERIALS
NOTES

CITY OF LIVERMORE
STANDARD DETAIL

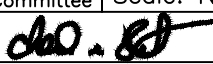
Dwn: M-W	Date: May-13	No.
Spec. Ckd: Committee	Scale: None	G-4B
 City Engineer		

Date:	By:	Rev:
-------	-----	------

CONCRETE CLASS USE TABLE		
TYPE OF CONSTRUCTION	CONCRETE CLASS	Maximum Slump ± 1 Inch
Street Surface Improvements (See Note 1)		
Curb, Gutter, Sidewalk, Driveways	3	4
Commercial/Industrial Driveways, Bus Turnouts, Valley Gutter	Minor Concrete	4
Extruded Curb	1	2
Sewer & Storm Drain Facilities		
Pipe Collars, Beam Support of Pipe, Pre-Cast Maintenance Hole Base, Storm Water Inlets	2	4
V-Ditches	3	4
Cast-In-Place Pipe	1	2
Reinforced Structures		
Retaining Walls Channels and Boxes	2	4
Water System Facilities		
Thrust Blocks, Valve Supports	2	4
Miscellaneous		
Street Light and Traffic Signal Foundations	2	4
Survey Monuments, Fence and Guardrail Post Foundations	4	4

Class 1 concrete shall contain not less than 675 pounds of Portland Cement per cubic yard
 Class 2 concrete shall contain not less than 590 pounds of Portland Cement per cubic yard
 Class 3 concrete shall contain not less than 505 pounds of Portland Cement per cubic yard
 Class 4 concrete shall contain not less than 420 pounds of Portland Cement per cubic yard
 Minor concrete shall contain not less than 550 pounds of Portland Cement per cubic yard
 unless otherwise specified in the specifications or the special provisions.

NOTE:

1. For surface improvements, use 3/4 lb. lamp black per cubic yard
2. Fly Ash 15% max per CT Sec 90 sewer only

User note:

These details shall be used in conjunction with all the City standard details and specifications. Refer to the City standard specifications for the materials, installation, testing, protective coatings, and other requirements.

Date	By	Rev.

CONCRETE CLASS
USE TABLE

CITY OF LIVERMORE
STANDARD DETAIL

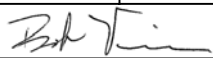
Dwn: MM	Date: Nov-22	NO. G-5
Ckd: Spec. Committee	Scale: NONE	
 City Engineer		

ABBREVIATIONS

AB = aggregate base
 ABS = Acrylonitrile-Butadiene-Styrene pipe
 AC = asphalt concrete
 AWWA = American Water Works Association
 Caltrans = State of California, Department of Transportation
 CF = cubic foot (feet)
 cl. = clear
 CLSM = Controlled low strength materials
 conc. = concrete
 const. = construction
 CIP = cast-in-place
 CIPCP = cast-in-place concrete pipe
 CVC = California Vehicle Code
 C&G = curb & gutter
 CL = centerline
 Detail x = Caltrans striping designation
 DF = douglas fir
 dia. = diameter
 DIP = ductile iron pipe
 dist. = distance
 DWY = driveway
 elev. = elevation
 E.P. = edge of pavement
 exist. = existing
 FC = face of curb
 FL = flow line
 galv. = galvanized
 HDPE = corrugated high density polyethylene nonpressure pipe
 HPS = high pressure sodium
 I.D. = inside diameter
 i.p. = iron pipe
 LCC = Livermore City Code
 LPD = Livermore Police Department
 LS = registered land surveyor
 LSE = landscape easement
 max. = maximum
 mech = mechanical
 MH = maintenance hole
 min. = minimum
 MLCSP = mortar-lined and mortar-coated steel pipe
 mph = miles per hour
 O.C. = on center

O.D. = outside diameter
 PCC = portland cement concrete
 PE = polyethylene plastic pipe
 PL = property line
 pt. = point
 PUE = public utilities easement
 PVC = polyvinyl chloride pipe
 PVCpp = PVC pressure pipe
 PVCsdnpp = PVC storm drain nonpressure pipe
 R = radius
 RCE = registered civil engineer
 RCP = reinforced concrete pipe
 RCPP = reinforce concrete pressure pipe
 RCP(PVCL) = reinforced concrete pipe (PVC lined)
 req'd = required
 (rt) = right
 R/W = right of way
 "s" = slope
 SD = storm drain
 Sch. = schedule
 sq. = square
 SS = sanitary sewer
 std. = standard
 SW = sidewalk
 SWE = sidewalk easement
 T = telephone
 TC = top of curb
 T.V. = television
 typ. = typical
 T&B = top & bottom
 VCP = vitrified clay pipe
 W = water
 WRD = Water Resources Division
 w/ = with
 O = diameter
 (lt) = left

User note:
 These details shall be used in conjunction with all the City standard details and specifications. Refer to the City standard specifications for the materials, installation, testing, protective coatings, and other requirements.

ABBREVIATIONS

CITY OF LIVERMORE
 STANDARD DETAIL

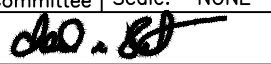
Dwn: KY	Date: May-13	NO. G-6
Ckd: Spec. Committee	Scale: NONE	
 City Engineer		

G07.DWG

Date	By	Rev.